



MVE Tech Tips



A monthly publication for the MVE Biological Products Distributors

April 2005

Each month we investigate the design changes to various models and the differences among the same model types. This month we will review the 1520HE series. There are 4 type of 1520HE units of which can be basic, full auto, or full auto with BB and GB. These are all offered in 240 volt as well.

They are:

	1520HE	1520 Eterne	1520HE+	1520HE GEN2
LN2 Holding Capacity				
Liq. Cap	756ltr	756 ltr	797ltr	756 ltr
Vapor Cap	133ltr	133 ltr	133ltr	113 ltr
Static ER	4.5 ltr/day	4.5 ltr/day	4.5 ltr/day	4.5 ltr/day
Container Dimensions				
Neck I.D.	17.5"	17.5"	17.5"	17.5"
OAH Basic	53.84"	54.9"	56.9"	54.9"
OAH Auto	60.8"	60.8"	62.8"	60.8"
Liftover Ht.	53.2"	53.2"	55.2"	53.2"
Outside Dia.	42"	42"	42"	42"
Useable Height	30.3"	30.3"	30.3"	30.3"
Internal Dia	38.47"	38.47"	38.47"	38.47"
Weight Empty	1386#est	1367# est.	1386# est	1367# est
Weight Full	2807#est	2714# est	2807# est	2714 est.
Storage Working Capacity				
Racks Large	24	24	24	24
Mini	8	8	8	8
2 ml Vials In Racks	31200 13-2	31200 13-2	33600 14-2	33800 13-2
2 ml Vials In Mini	2600 13-2	2600 13-2	2800 14-2	5200 13-2
Temp At Top	-150C	-190C	-150C	-150C

All 1520HE models have 9" of LN2 storage space beneath the turntable. The GEN 2 can store additional large and mini racks due to reconfigured divider design.

Please See Attached References:

B-11376011
 B-11894644
 B-11937755
 B-C00248

END OF FISCAL YEAR SALE - REFURBISHED BIOLOGICAL UNITS

REFURBISHED/ SLOW MOVING MVE/XLC UNITS IN STOCK AS OF 3/23/05

SALE PRICES - NO OTHER DISCOUNTS APPLICABLE

WARRANTY – 2 YEAR VACUUM

6 MONTHS CONTROLLER

QTY	PN#	DESCRIPTION	SN#	SELLING PRICE
1	10763976R	RPL XLC 500 F-GB-BB SQUARE CORNER CABINET	CDRA96H127	\$4217.00*
1	10980663R	RPL CC/Thermo 50LP		\$1111.50*
4	10980671R	RPL CC/Thermo 35LP		\$1029.00
2	11003881R	RPL Bio 1 w/Auto Fill		\$3047.50
1	11499783R	RPL MVE 600 FD GB BB		\$4942.00
1	11004411R	RPL MVE 230FD GB BB		\$3540.50
3	10804205	MVE XLC 1200 Sq Corner Cabinet		\$6,200.00

***SALE PRICES - NO OTHER DISCOUNTS APPLICABLE**

ALUMINUM UNITS: IN STOCK AS OF 3/23/05

***SALE PRICES - NO OTHER DISCOUNTS APPLICABLE**

WARRANTY – 1 YEAR VACUUM

QTY	PN#	DESCRIPTION	SELLING PRICE
19	11781800R	RPL Cryo Shipper XC (no c/c, no prot carton –units only)	\$288.00
1	11901162R	RPL Millennium II	\$373.00
3	10743035R	RPL SC 33/26	\$459.50
1	991853R	RPL XC 22/5	\$441.00
2	991803R	RPL XC 43/28	\$589.00
1	11052674R	RPL Cryo Sys 8	\$500.00

THE FOLLOWING UNITS ARE NEW, BUT CONSIDERED OBSOLETE OR OVER STOCK. ALL COME WITH A 3YR VACUUM WARRANTY

(THE XC 35/5V IS A VAPOR SHIPPER, HOWEVER NO PROTECTIVE CARTON IS AVAILABLE.)

5	11198761	XC 35/5V	\$500.00*
---	----------	----------	-----------

***SALE PRICES - NO OTHER DISCOUNTS APPLICABLE**

DATA LOGGER REPAIR POLICY

When contacting customer service for calibrating or replacing battery on a data logger, please remember to include return authorization and the serial number on the outside of the package. It will then be sent to:

Chart Ind. AI

C/O Kevin Thissen

201, 7th St. N.W.

New Prague, Mn. 56071

Calibration price is \$200 each. Replacing battery will run \$350 each.

Each time a battery is replaced the logger also needs to be recalibrated. If battery life is less than 50%, a customer service representative will contact you for battery replacement. We strongly encourage changing out battery at this time.

Warranty of data loggers is one year from order shipment date. Calibrating or battery replacement will not extend the logger warranty.

QUESTION AND ANSWER

Q. *Why was the lid switch added to the 511?*

A. The lid switch was added to the 511 effective June 04. It was added for UL compliance. When the MDC stand-alone power supplies are consumed (and the SMC valve approved for UL use), we will begin applying the same UL label that the cabinets get. This applies to all models. The open top freezer, 230, 511, 611, 1411, 1841 are required by UL to have a lid switch to stop filling when the lid is open just like the cabinet models. The stock series and the HE/Eterne series do not require it because there is a standard platform between the user and the liquid discharge port.

Q. *The Health and Safety officer has told us that, per regulation, the freezers cannot use extension cords. Is it a UL thing?*

A. The UL standard applied to cabinet models limited the power cord to 3 ft. in length. (We don't know why, and neither did the UL engineer that worked on the project. That is simply how the standard was written.) We included the extension cord because there were complaints that the 3 ft. cord was not long enough. The UL standard does not specify one way or another about using an extension cord with the unit. We started including it due to overwhelming distributor request. We are not familiar with any regulation prohibiting the use of an extension cord with the unit. However, that does not mean that there is not one that we are not aware of. As far as wire specs are concerned, the extension cord is made from the same cord that the attached power cord is made from, so the wire specs are identical. As we change over to the new Jerome power supply across the board, we will discontinue the extension cord.

If the customer cannot use the extension cord, they have three options. If the 3-foot cord can reach the outlet, they can plug the main cord directly to the outlet. They can have an outlet installed close enough to the unit that the 3-foot cord can reach it. They can replace the MDC power supply with the new Jerome power supply. The kit to retrofit the new Jerome power supply in place of the MDC power supply is 11943012.

New addresses

Chart Bio-Medical Office
1800 Sandy Plains Industrial Parkway
Marietta, Ga. 30066
770 425-4470

Burnsville Satellite Office
Chart Ind.
14101 W Southcross Drive
Suite 300
Burnsville, Mn. 55337
952 882-5000

AI Warehouse
302 2nd St. NW
New Prague, Mn 56071
952 758-7702

Customer Service 800 482-2473
770 257-1299
888 932-2473 fax

Technical Service 866 819-5897
952 641-6115
612 382-6678
952 882-5172 fax

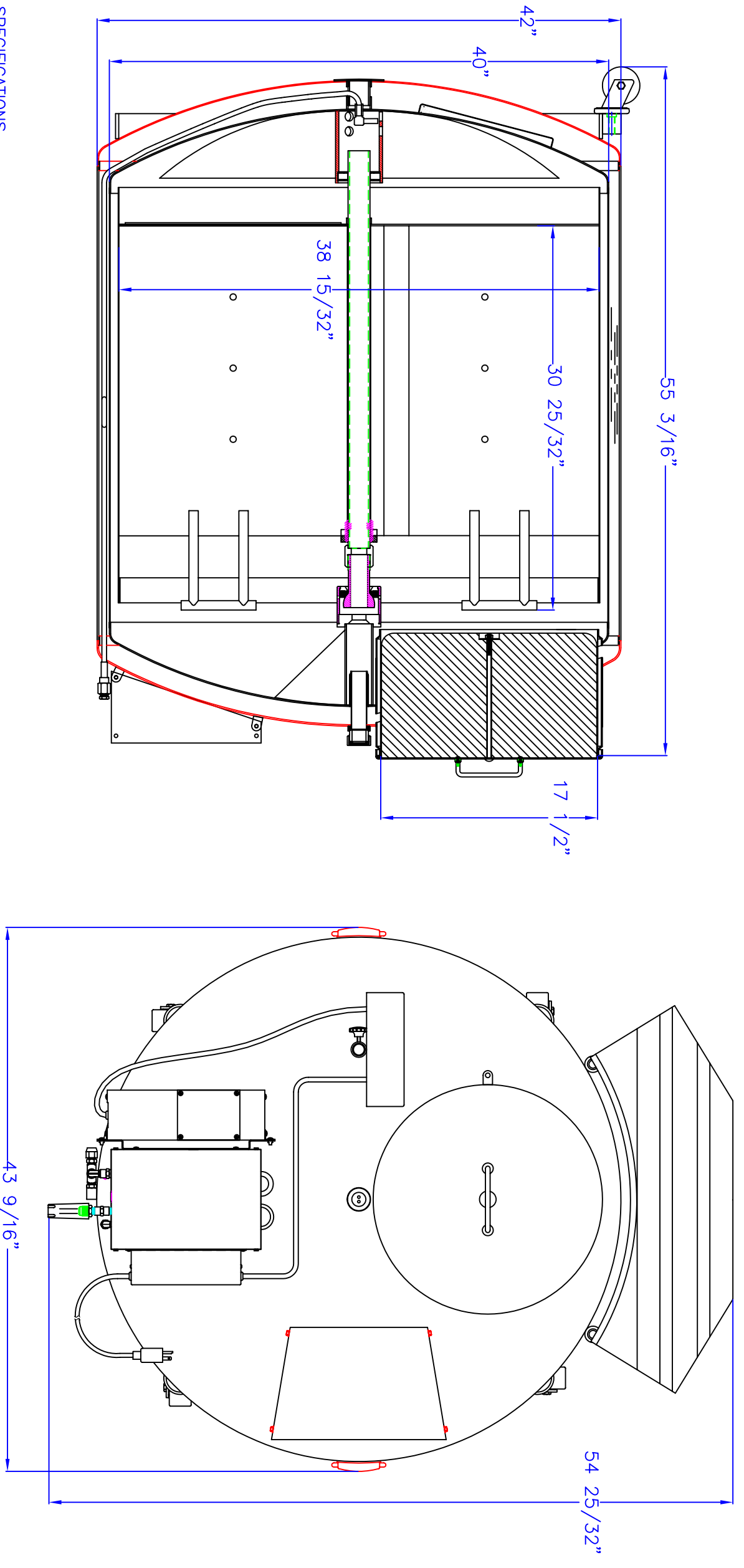

SPECIFICATIONS
 LN₂ CAPACITY LIQUID FULL _____ 797 LITERS
 STATIC HOLDING TIME FULL _____ 177 DAYS
 LN₂ CAPACITY VAPOR STORAGE _____ 133 LITERS
 STATIC HOLDING TIME VAPOR _____ 29 DAYS
 STATIC EVAPORATION RATE _____ 4.5 LITERS/DAY

CONTAINER DIMENSIONS
 NECK OPENING _____ 17.5in./444.5mm
 OVERALL HEIGHT BASIC _____ 56.9in./1445.8mm
 OVERALL HEIGHT AUTO-FILL _____ 62.8 in./1595.7mm
 LIFTOVER HEIGHT _____ 55.2in./1402.7 mm
 OUTSIDE DIAMETER _____ 42in./1066.8mm
 USABLE/WORKING HEIGHT _____ 30.8in./781.8mm
 INTERNAL DIAMETER (TRAY) _____ 38.47in./977.14 mm
 WEIGHT EMPTY _____ 1386lbs./629kg ESTIMATED
 WEIGHT FULL _____ 2807lbs./1273kg ESTIMATED

STORAGE WORKING CAPACITY
 INVENTORY RACKS - STANDARD _____ 24
 MINI _____ 8
 1.2 & 2.0 ml AMPULES IN RACKS _____ 33,600
 1.2 & 2.0 ml AMPULES IN MINI RACKS _____ 2,800

REV	APPV	ECR	REVISION DESCRIPTION	BY	DATE

MAT'L

FINISH P/N 11894644

APP'VD	DATE	PROJLEADER	DATE
JSB	4/12/04	JSB	4/14/04

UNLESS OTHERWISE SPECIFIED DIMENSIONS ARE IN INCHES.
 TOLERANCES:
 FRACTIONS ± 1/16"
 ANGLES ± 1°
 2 PLACE DECIMAL ± .031
 3 PLACE DECIMAL ± .015

SCALE: NA

DO NOT SCALE DRAWING

SHEET: 1 of 1

APPLICATION ORIGINAL ECR/ER

USED ON 205759

CHART INDUSTRIES, INC.
 CANTON, GEORGIA 30114

CHART INDUSTRIES, INC.
 CANTON, GEORGIA 30114

TITLE: MVE 1520HE+ SPECIFICATION DWG

DRAWING NO. B-11894644

REV: _____

THE MATERIALS AND INFORMATION, INCLUDING THE PRINCIPLES OF DESIGN PRESENTED BY THIS PRINT, IS THE EXCLUSIVE PROPERTY OF MINNESOTA VALLEY ENGINEERING, AND IS CONFIDENTIAL INFORMATION. ACCORDINGLY, THIS INFORMATION IS SUBMITTED TO YOU WITH THE AGREEMENT THAT IT IS NOT TO BE REPRODUCED, COPIED, OR LOANED, IN PART OR IN WHOLE, NOR IS THE INFORMATION TO BE RELAYED TO ANY COMPANY. ACCEPTANCE OF THIS DRAWING WILL BE CONSTRUED AS AN AGREEMENT TO THE ABOVE.

DESIGNATES A NOTE REFERENCE.

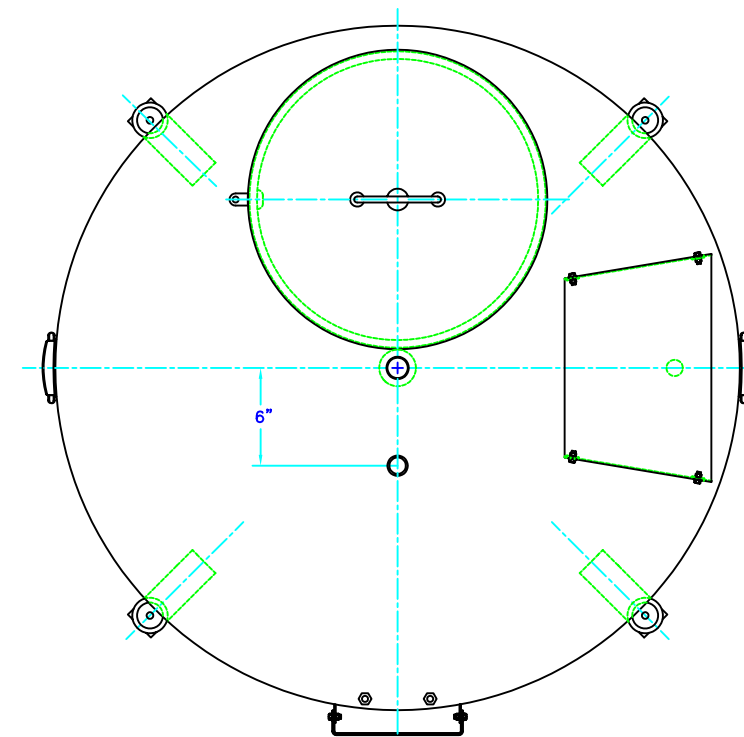
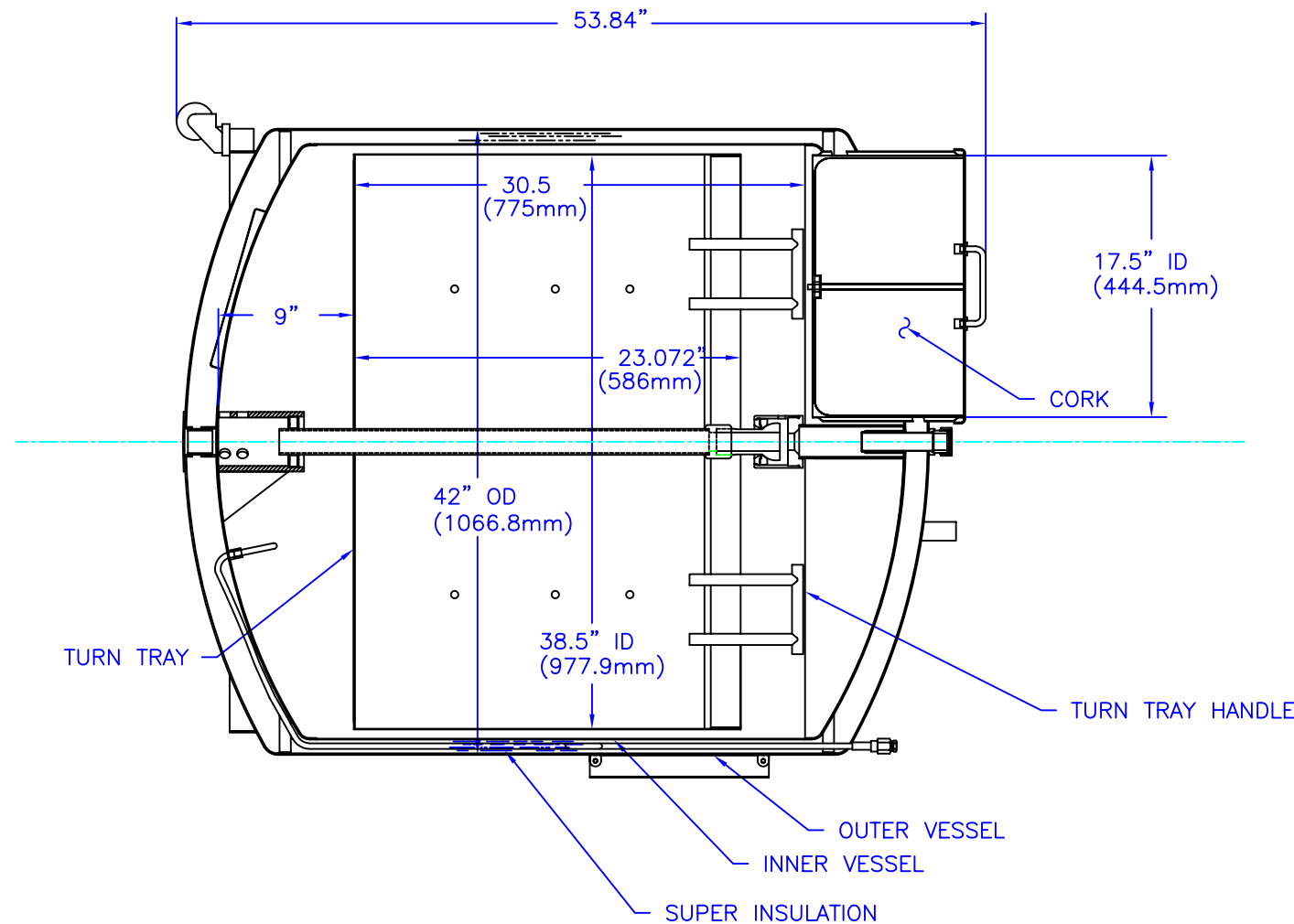

STORAGE CAPACITY

1/2 cc STRAWS (10/CANE).....33,480
 2ml PLASTIC VIALS ON CANE.....18,144
 SUC-1 CANISTERS.....108
 # OF INVENTORY RACKS.....(20) 100 CELL 13-2
 # OF 2ml AMPULES IN RACKS.....26,000

PERFORMANCE

LN² CAPACITY (LITER).....620 l
 STATIC HOLDING TIME (DAYS).....135
 STATIC EVAPORATION RATE (LITERS/DAY)....4.5

DIMENSIONS

NECK OPENING (mm).....17.5"/444.5
 OVERALL HEIGHT (mm).....53.84"
 WORKING HEIGHT (mm).....30.5"/775
 OUTSIDE DIAMETER (mm).....42"/1066
 INSIDE DIAMETER (mm).....38.5"/977.9
 WEIGHT EMPTY (kg).....620
 WEIGHT FULL (kg).....1720

REV	APPV	ECR	REVISION DESCRIPTION	BY	DATE	APP'VD	DATE		
C		201,626	REVISED SECTION AND TOP VIEW	LF	4-10-96	DRAWN BY JVT	12-8-92		
B	JB	201,337	REV PER ECR	JBP	12-4-95	CHECKED BY MK	1-2-96	USED ON	
A		200,178	REV,D AND REDRAWN	JVT	4-15-93	PROJ.ENGR. JB	4-15-95	APPLICATION	ORIGINAL ECR/ER
<p>THE MATERIALS AND INFORMATION, INCLUDING THE PRINCIPLES OF DESIGN PRESENTED BY THIS PRINT, IS THE EXCLUSIVE PROPERTY OF MINNESOTA VALLEY ENGINEERING, AND IS CONFIDENTIAL INFORMATION. ACCORDINGLY, THIS INFORMATION IS SUBMITTED TO YOU WITH THE AGREEMENT THAT IT IS NOT TO BE REPRODUCED, COPIED, OR LOANED, IN PART OR IN WHOLE, NOR IS THE INFORMATION TO BE RELAYED TO ANY COMPANY. ACCEPTANCE OF THIS DRAWING WILL BE CONSTRUED AS AN AGREEMENT TO THE ABOVE.</p> <p># DESIGNATES A NOTE REFERENCE.</p>						<p>MAT'L</p> <p>FINISH P/N 10779214</p>		<p>UNLESS OTHERWISE SPECIFIED DIMENSIONS ARE IN INCHES. TOLERANCES: FRACTIONS ± ANGLES ± 2 PLACE DECIMAL ± .031 3 PLACE DECIMAL ± .015</p>	
						<p>MVE INC. CANTON, GEORGIA 30114</p> <p>TITLE: XLC-1520 HE, SPEC</p>			
						<p>DRAWING NO. B-C00248</p>		<p>REV: C</p>	
						<p>SCALE: N/A</p>		<p>DO NOT SCALE DRAWING</p>	
						<p>SHEET: 1 of 1</p>			